



DINO-POWER

Operation Manual



DP-X3 DP-X5 **Electric Airless Paint Sprayer** www.dpairless.com



Important Safety Instructions

Read all warnings and instructions in this manual, related manuals, and on the unit. Be familiar with the controls and the proper usage of the equipment. Save these instructions. Read carefully and practice good safety habits.

Before You Spray

WARNING

FIRE AND EXPLOSION HAZARD

DP-X3/DP-X5 Models:

- Use only non-flammable or water-based/oil-based materials, or non-flammable paint thinners. Do not use materials having flash points lower than 100° F (38° C). This includes, but is not limited to, acetone, xylene, toluene, or naphtha. For more information about your material, request Safety Data Sheet (SDS) from the supplier.
- Spraying flammable or combustible materials in a factory or fixed location must comply with NFPA 33 and OSHA 1910.94(c) requirements in the USA and with all similar local regulations in other countries.

Review Warnings for Important Safety Information.

**Not approved for use in explosive atmospheres or hazardous locations.
For portable airless spraying of architectural paints and coatings.**

When pump is stored with non-freezing fluid. Pump damage will occur if water or latex paint freezes in pump.

**Damage to plastic parts may result if impact occurs in low temperature conditions.
Changes in paint viscosity at very low or very high temperatures can affect sprayer performance.**

Contents

Before You Spray	1
Warnings	3
Know Your Sprayer	6
Setup	7
Start Up	9
Pressure Relief Procedure.....	9
How to Spray	12
Adjust Pressure Control.....	13
Spray Techniques.....	13
Clear Tip Clog.....	14
Cleanup	15
Storage	17
Reference	19
Spray Tip Selection.....	19
Cleaning Fluid Compatibility.....	20
Static Grounding Instructions (Oil-Based materials).....	20
Maintenance	22
Troubleshooting	25
Explosion View and Spare Parts List	29
DP Information	31

Warnings

The following warnings are for the setup, use, maintenance, and repair of this equipment. The exclamation point symbol alerts you to a general warning and the hazard symbols refer to procedure-specific risks. When these symbols appear in the body of this manual or on warning labels, refer back to these Warnings. Product-specific hazard symbols and warnings not covered in this section may appear throughout the body of this manual where applicable.

WARNING



FIRE AND EXPLOSION HAZARD

Flammable fumes, such as solvent and paint fumes, in work area can ignite or explode. To help prevent fire and explosion:



DP-X3/DP-X5 Models:



- Do not spray or clean with materials having flash points lower than 100°F (38° C). Use only non-flammable or water-based materials, or non-flammable paint thinners. For complete information about your material, request the Safety Data Sheet (SDS) from the material distributor or retailer.
- Do not spray combustible materials near an open flame or sources of ignition such as cigarettes, motors, and electrical equipment.
- Do not spray combustible liquids in a confined area.
- Do not spray flammable or combustible materials near an open flame or sources of ignition such as cigarettes, motors, and electrical equipment.
- Do not spray flammable or combustible liquids in a confined area.
- Paint or solvent flowing through the equipment is able to result in static electricity. Static electricity creates a risk of fire or explosion in the presence of paint or solvent fumes. All parts of the spray system, including the pump, hose assembly, spray gun, and objects in and around the spray area shall be properly grounded to protect against static discharge and sparks. Use Graco conductive or grounded high-pressure airless paint sprayer hoses.
- Verify that all containers and collection systems are grounded to prevent static discharge. Do not use pail liners unless they are anti-static or conductive.
- Connect to a grounded outlet and use grounded extensions cords. Do not use a 3-to-2 adapter.
- Do not use a paint or a solvent containing halogenated hydrocarbons.
- Keep spray area well-ventilated. Keep a good supply of fresh air moving through the area.
- Sprayer generates sparks. Keep pump assembly in a well ventilated area a least 20 feet (6.1 m) from the spray area when spraying, flushing, cleaning, or servicing. Do not spray pump assembly.
- Do not smoke in the spray area or spray where sparks or flame is present.
- Do not operate light switches, engines, or similar spark producing products in the spray area.
- Keep area clean and free of paint or solvent containers, rags, and other flammable materials.
- Know the contents of the paints and solvents being sprayed. Read all Safety Data Sheets (SDSs) and container labels provided with the paints and solvents. Follow the paint and solvents manufacturer's safety instructions.
- Fire extinguisher equipment shall be present and working.

WARNING

SKIN INJECTION HAZARD



High-pressure spray is able to inject toxins into the body and cause serious bodily injury. In the event that injection occurs, **get immediate surgical treatment.**



- Do not aim the gun at, or spray any person or animal.
- Keep hands and other body parts away from the discharge. For example, do not try to stop leaks with any part of the body.
- Always use the nozzle tip guard. Do not spray without nozzle tip guard in place.
- Use DP nozzle tips.
- Use caution when cleaning and changing nozzle tips. In the case where the nozzle tip clogs while spraying, follow the **Pressure Relief Procedure** for turning off the unit and relieving the pressure before removing the nozzle tip to clean.
- Equipment maintains pressure after power is shut off. Do not leave the equipment energized or under pressure while unattended. Follow the **Pressure Relief Procedure** when the equipment is unattended or not in use, and before servicing, cleaning, or removing parts.
- Check hoses and parts for signs of damage. Replace any damaged hoses or parts.
- This system is capable of producing 2900 psi. Use DP replacement parts or accessories that are rated a minimum of 2900 psi.
- Always engage the trigger lock when not spraying. Verify the trigger lock is functioning properly.
- Verify that all connections are secure before operating the unit.
- Know how to stop the unit and bleed pressure quickly. Be thoroughly familiar with the controls.



EQUIPMENT MISUSE HAZARD



Misuse can cause death or serious injury.



- Always wear appropriate gloves, eye protection, and a respirator or mask when painting.
- Do not operate or spray near children. Keep children away from equipment at all times.
- Do not overreach or stand on an unstable support. Keep effective footing and balance at all times.
- Stay alert and watch what you are doing.
- Do not operate the unit when fatigued or under the influence of drugs or alcohol.
- Do not kink or over-bend the hose.
- Do not expose the hose to temperatures or to pressures in excess of those specified by DP.
- Do not use the hose as a strength member to pull or lift the equipment.
- Do not spray with a hose shorter than 25 feet.
- Do not alter or modify equipment. Alterations or modifications may void agency approvals and create safety hazards.
- Make sure all equipment is rated and approved for the environment in which you are using it.

ELECTRIC SHOCK HAZARD



This equipment must be grounded. Improper grounding, setup, or usage of the system can cause electric shock.



- Turn off and disconnect power cord before servicing equipment.
- Connect only to grounded electrical outlets.
- Use only 3-wire extension cords.
- Ensure ground prongs are intact on power and extension cords.
- Do not expose to rain. Store indoors.

Warnings

WARNING



PRESSURIZED ALUMINUM PARTS HAZARD

Use of fluids that are incompatible with aluminum in pressurized equipment can cause serious chemical reaction and equipment rupture. Failure to follow this warning can result in death, serious injury, or property damage.

- Do not use 1,1,1-trichloroethane, methylene chloride, other halogenated hydrocarbon solvents or fluids containing such solvents.
- Do not use chlorine bleach.
- Many other fluids may contain chemicals that can react with aluminum. Contact your material supplier for compatibility.



MOVING PARTS HAZARD

Moving parts can pinch, cut, or amputate fingers and other body parts.

- Keep clear of moving parts.
- Do not operate equipment with protective guards or covers removed.
- Pressurized equipment can start without warning. Before checking, moving, or servicing equipment, follow the **Pressure Relief Procedure** and disconnect all power sources.



TOXIC FLUID OR FUMES HAZARD

Toxic fluids or fumes can cause serious injury or death if splashed in the eyes or on skin, inhaled, or swallowed.

- Read MSDSs to know the specific hazards of the fluids you are using.
- Store hazardous fluid in approved containers, and dispose of it according to applicable guidelines.



PERSONAL PROTECTIVE EQUIPMENT

Wear appropriate protective equipment when in the work area to help prevent serious injury, including eye injury, hearing loss, inhalation of toxic fumes, and burns. This protective equipment includes but is not limited to:

- Protective eyewear, and hearing protection.
- Respirators, protective clothing, and gloves as recommended by the fluid and solvent manufacturer.

DP-X3 DP-X5

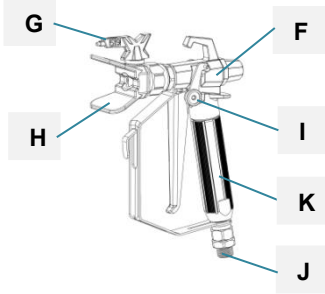
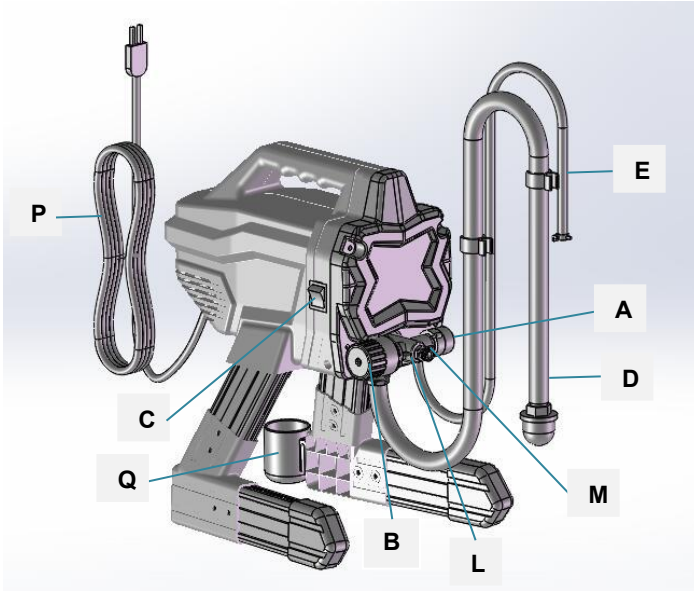

A	Prime/Spray Valve
B	Pressure Control Knob
C	ON/OFF Switch
D	Suction Tube
E	Drain Tube
F	Airless Spray Gun
G	Reversible Spray Tip
H	Tip Guard
I	Gun Trigger Lock
J	Gun Fluid Inlet Fitting

K	Gun Fluid Filter(inside handle)
L	Pump
M	Pump Fluid Outlet Fitting
N	Airless Hose
O	Suction Filter
P	Power Cord
Q	Suction Tube Drip Cup
See Quick Reference , page 21 for more information.	

Know Your Sprayer

Technical Specifications:

Model No.	DP-X3	DP-X5
Pressure Controlling	Mechanical	Mechanical
Motor Power	450W	650W
Max. Flow Rate	1.0L/min 0.26GPM	1.4L/min 0.36GPM
Max. Tip Size	0.017"	0.019"
Max. Pressure	200bar/2900psi	200bar/2900psi

Setup

When unpacking sprayer for the first time or after long term storage perform setup procedure.

Assemble Your Sprayer

1. Connect DP airless hose to fluid outlet. Use wrench to tighten securely.

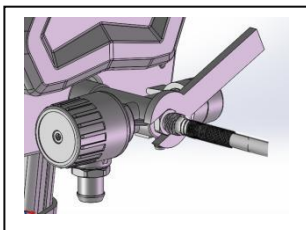

2. Connect other end of hose to gun.

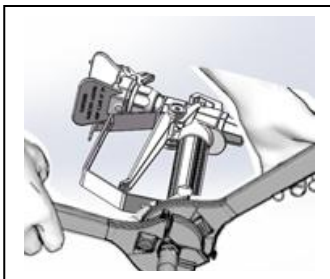

3. Use two wrenches to tighten securely. If hose is already connected, make sure connections are tight.
4. Engage trigger lock.



5. Remove tip guard. Be careful tip seal may fall out when tip guard is removed.

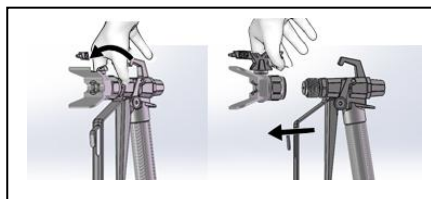

6. Turn pressure control knob all the way left (counter-clockwise) to lowest setting.

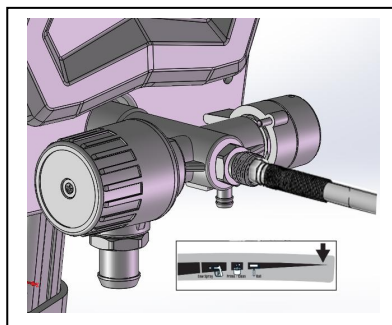

7. After long term storage check inlet strainer for clogs and debris.

Strain the Paint

Previously opened paint may contain dried paint or other debris. To avoid priming problems and spray tip clogs it is recommended to strain the paint before using. Paint strainers are available where paint is sold. Stretch a paint strainer over a clean pail and pour the paint through the strainer to capture any dried paint and debris before spraying.



Start Up

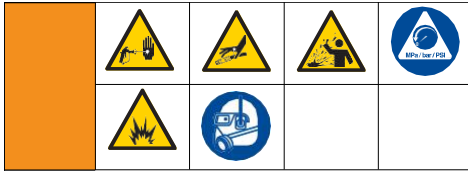

Pressure Relief Procedure



Follow the Pressure Relief Procedure whenever you see this symbol.

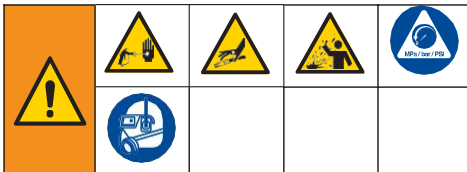

This equipment stays pressurized until pressure is manually relieved. To help prevent serious injury from pressurized fluid, such as skin injection or splashed fluid, follow the **Pressure Relief Procedure** whenever sprayer is stopped and before sprayer is cleaned or checked, and before equipment is serviced.

1. Turn ON/OFF switch to the **OFF** position.

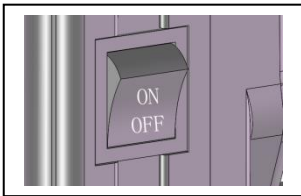

1. Engage the trigger lock. Always engage the trigger lock when sprayer is stopped to prevent the gun from being triggered accidentally.

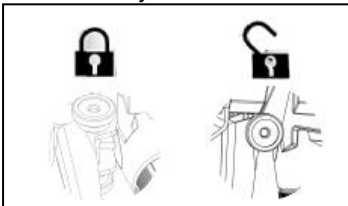

2. Turn pressure control knob to lowest setting.

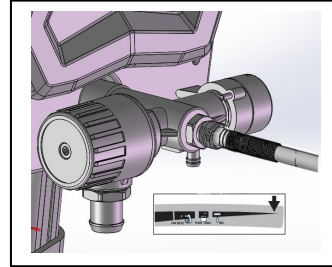

3. Put drain tube into a waste pail and turn Prime/Spray valve in PRIME position (drain) to relieve pressure.

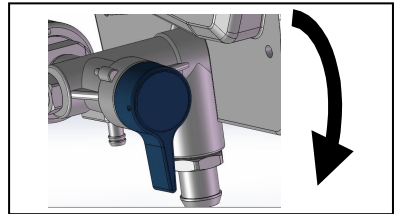

4. Hold the gun firmly to a pail. Point gun into pail. Disengage the trigger lock and trigger the gun to relieve pressure.
5. Engage the trigger lock.



6. If you suspect the spray tip or hose is clogged or that pressure has not been fully relieved:
 - a. VERY SLOWLY loosen the tip guard retaining nut or the hose end coupling to relieve pressure gradually.
 - b. Loosen the nut or coupling completely.
 - c. Clear airless hose or spray tip obstruction.

1. Turn Prime/Spray valve down to PRIME position.

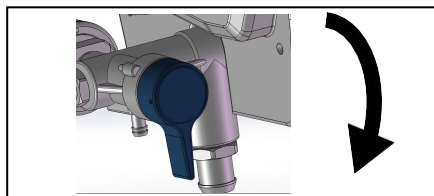

2. Plug power supply cord into a properly grounded electrical outlet.
3. Align setting indicator with Prime/Clean setting on pressure control knob.

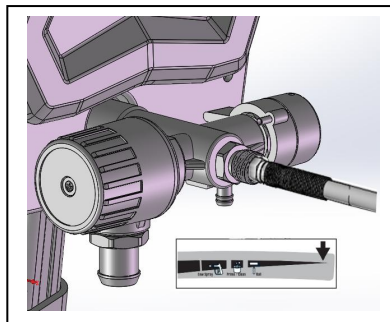

4. Turn ON/OFF switch to **ON** position.

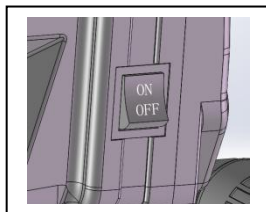

Start Up

- When sprayer starts pumping, flushing solvent and air bubbles will be purged from system. Allow fluid to flow out of drain tube, into waste pail, for 30 to 60 seconds.
- Turn ON/OFF switch to **OFF** position.



- Inspect for leaks. If leaks occur, perform **Pressure Relief Procedure**, page 9, then tighten all fittings and repeat **Start Up**. If there are no leaks continue with the next step.

Fill Pump

- Move suction tube to paint pail and submerge suction tube in paint.



- Turn ON/OFF switch to **ON** position.
- Wait to see paint coming out of drain tube.
- Turn ON/OFF switch to **OFF** position.

NOTE: Some fluids may prime faster if the ON/OFF Switch is momentarily turned off so the pump can slow and stop. Turn ON/OFF switch on and off several times if necessary.

Fill Gun and Hose

- Hold gun against waste pail. Point gun into waste pail.
 - Disengage trigger lock.
 - Pull and hold gun trigger.
 - Turn Prime/Spray valve horizontal to **SPRAY** position.
 - Turn ON/OFF switch to **ON** position.

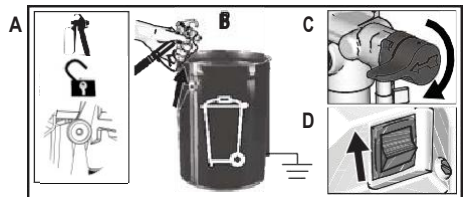

- Trigger gun into waste pail until only paint comes out of the gun.
- Release trigger. Engage trigger lock.
- Transfer drain tube to paint pail and clip to suction tube.

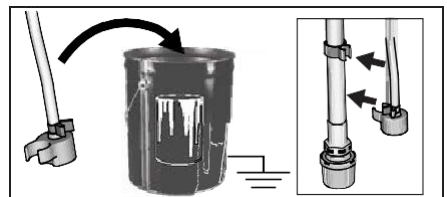

NOTE: When motor stops, sprayer is ready to paint. If motor continues to run, sprayer is not properly primed. Repeat **Fill Pump** and **Fill Gun and Hose**.

How to Spray

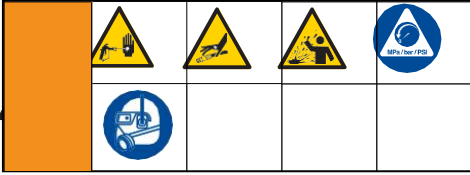

Spray Tip Installation

To prevent spray tip leaks make certain spray tip and tip guard are installed properly.

1. Perform **Pressure Relief Procedure**, page 9.
2. Engage trigger lock.
3. Verify spray tip and tip guard parts are assembled in the order shown.

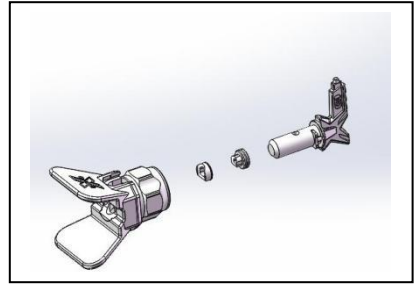
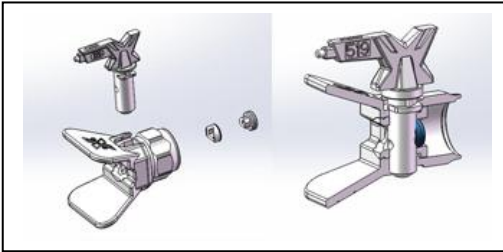

- b. Spray tip must be pushed all the way into the tip guard. Turn spray tip to push down.

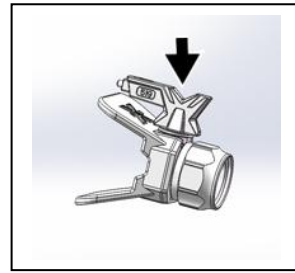

- c. Turn the arrow shaped handle on the spray tip forward to the spray position.
4. Screw spray tip and tip guard assembly onto the gun and tighten.

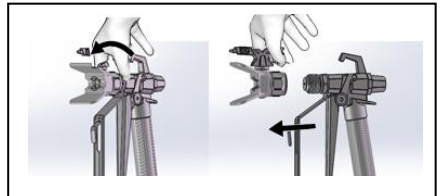

How to Spray

Adjust Pressure Control

The pressure control knob allows for infinite pressure adjustment. To reduce overspray, always start at the lowest pressure setting and increase pressure to the minimum setting that results in an acceptable spray pattern.

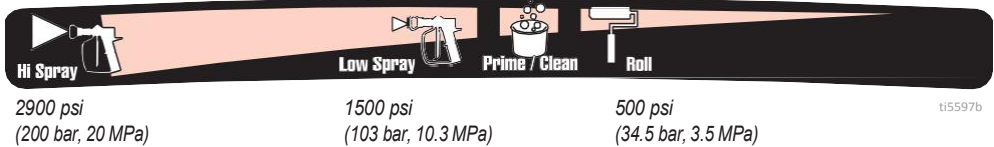

To select function, align symbol on pressure control knob with setting indicator on sprayer.

Tip and Pressure Selection

See table for recommended spray pressure for your material. Refer to paint (material) can for manufacturer's recommendations.

Maximum tip hole sizes supported by the sprayer:

DP-X3: 0.017 in. (0.43 mm)

DP-X5: 0.019 in. (0.48 mm)

	Coatings				
	Interior Stains/ Interior & Exterior Clears	Exterior Solid Stains	Primers	Interior Latex Paints	Exterior Latex Paints
Spray Pressure	Low Spray	High Spray	High spray	High Spray	High Spray
Tip hole Size					
0.011 in. (0.28 mm)	X				
0.013 in. (0.33 mm)	X	X	X	X	
0.015 in. (0.38 mm)		X	X	X	X
0.017 in. (0.43 mm)			X	X	X
0.019 in. (0.48 mm)					X

Spray Techniques

Use a piece of scrap cardboard to practice these basic spraying techniques before you begin spraying the surface.

- Hold gun 12 in. (30 cm) from surface and aim straight at surface. Tilting gun to direct spray angle causes an uneven finish.
- Flex wrist to keep gun pointed straight. Fanning gun to direct spray at angle causes uneven finish.

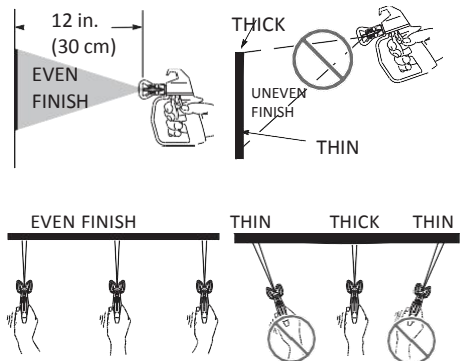

Triggering Gun

Pull trigger after starting stroke. Release trigger before end of stroke. Gun must be moving when trigger is pulled and released.

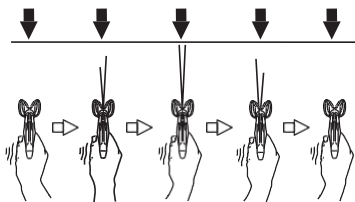

TI2037A

Aiming Gun

Aim center of spray of gun at bottom edge of previous stroke, overlapping each stroke by half.

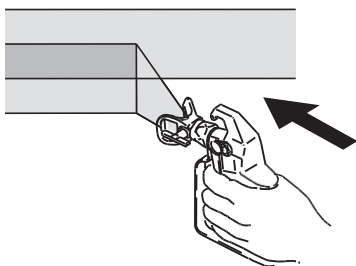

Spray Pattern Quality

A good spray pattern is evenly distributed as it hits the surface.

- Spray should be atomized (evenly distributed, no gaps at edges).

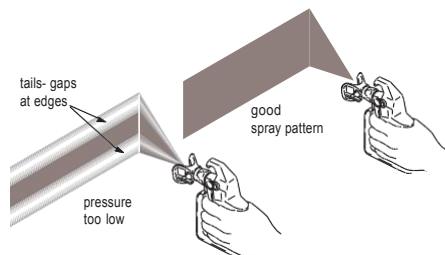

If tails persist when spraying at the highest spray pressure:

- Spray tip may be worn. See **Tip and Pressure Selection**, page 13.
- A smaller spray tip may be needed.

- Material may need to be thinned. If material needs to be thinned follow manufacturer's recommendations.

Clear Tip Clog

In the event that particles or debris clog the spray tip, this sprayer is designed with a reversible spray tip that quickly and easily clears the particles without disassembling the sprayer.

See **Strain the Paint**, page 8 for additional information.

1. Engage trigger lock. Rotate spray tip to unclog position. Disengage trigger lock. Trigger gun at waste area to clear clog.

UNCLOG

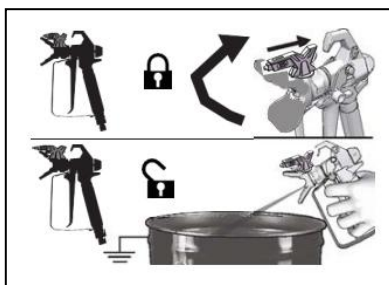

NOTE: If spray tip is difficult to rotate when turning to the unclog position perform, **Pressure Relief Procedure**, page 9, then turn Prime/Spray valve to spray position and repeat step 1.

2. Engage trigger lock. Rotate spray tip back to spray position. Disengage trigger lock and continue spraying.

SPRAY



Cleanup

Cleaning the sprayer after each use results in a trouble free start up the next time the sprayer is used.



Cleaning from a Pail

- For short term shutdown periods (overnight to two days) refer to **Short Term Storage**, page 17.
 - See **Cleaning Fluid Compatibility**, page 20 for information on flushing/cleaning fluids and **Static Grounding Instructions (Oil-Based materials)**, page 20.
1. Perform **Pressure Relief Procedure**, page 9.
 2. Remove spray tip and tip guard assembly from gun and place in waste pail.

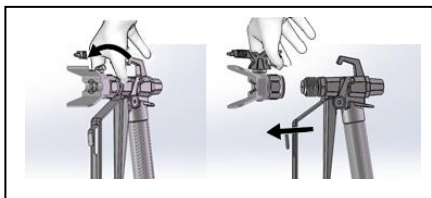

3. Lift suction tube and drain tube from paint pail. Let paint drain into the pail.
4. Separate drain tube (smaller) from suction tube (larger).

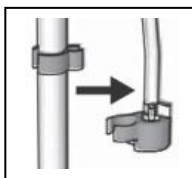

5. Place empty waste and flushing fluid pails side by side.
6. Place suction tube in flushing fluid. Use water for water based paint and mineral spirits or compatible oil-based flushing solvent for oil-based paint. Place drain tube in waste pail.



7. Turn pressure control knob to the Prime/Clean setting.

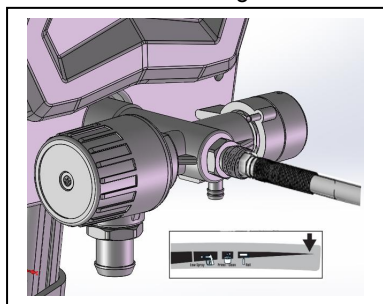

8. Turn Prime/Spray valve down to PRIME position.

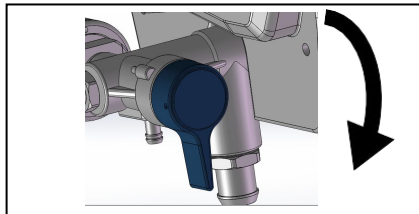

9. Turn ON/OFF switch to **ON** position.
10. Flush until approximately 1/3 of the flushing fluid is emptied from the pail.

11. Turn ON/OFF switch to **OFF** position.

NOTE: Step 12 is for returning paint in hose to paint pail. One 50 ft (15 m) hose holds approximately 1 quart (1 liter) of paint.

12. To recover paint in hose, point gun into paint pail while holding gun firmly to the pail.
 - a. Disengage trigger lock.
 - b. Pull and hold down trigger.
 - c. Turn Prime/Spray valve horizontal to **SPRAY** position.
 - d. Turn ON/OFF switch to **ON** position.
 - e. Continue to hold gun trigger until you see paint diluted with flushing fluid starting to come out of gun.

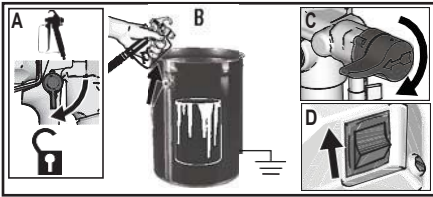

13. While continuing to trigger gun, quickly move gun to redirect spray into waste pail. Continue triggering gun into waste pail until flushing fluid dispensed from gun is relatively clear.

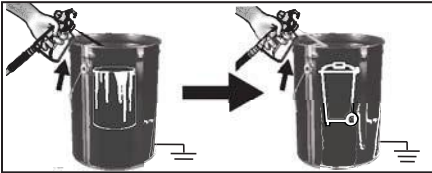

14. Turn pressure control knob to the low- est setting.
15. Stop triggering gun. Engage the trigger lock.

Turn Prime/Spray valve down to **PRIME** position.

16. Turn ON/OFF switch to **OFF** position.

Clean the Gun

1. Clean gun fluid filter with water or flushing fluid and a brush every time you flush the system. Replace gun filter if damaged.

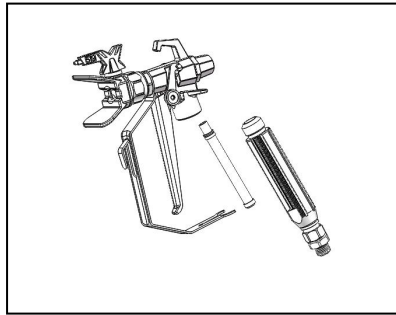

2. Remove spray tip and tip guard and clean with water or flushing fluid and a brush.

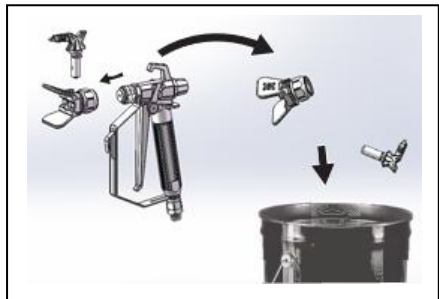

3. Wipe paint off outside of gun using a soft cloth moistened with water or flushing fluid.

Storage

Storage

With proper storage, the sprayer will be ready to use the next time it is needed.

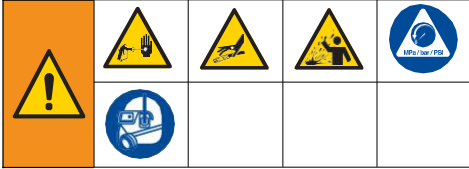

Short Term Storage

(up to 2 days)

1. Perform **Pressure Relief Procedure**, page 9.
2. Leave suction tube and drain tube in paint pail.

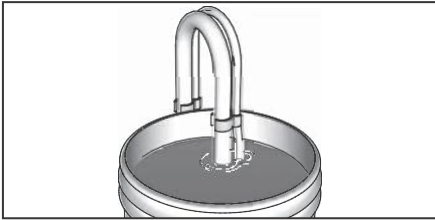

3. Cover paint and pail tightly with plastic wrap.

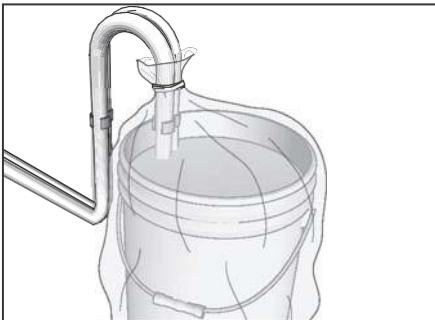

4. Engage trigger lock.

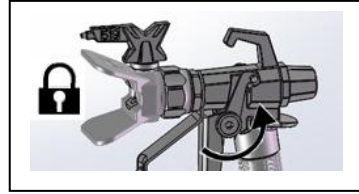

5. Leave gun attached to hose.
6. Remove tip and guard and clean with water or flushing fluid and a brush.
7. Wipe paint off outside of gun using a soft cloth moistened with water or flushing fluid.

Long Term Storage

(more than 2 days)

Pump armor fluid protects the sprayer against freezing and corrosion.

- Before storing sprayer make sure all water is drained out of sprayer.
 - Do not allow water to freeze in sprayer.
 - Do not store sprayer under pressure.
 - Store sprayer indoors.
1. Perform **Pressure Relief Procedure**, page 9.
 2. Place suction tube in Pump Armor fluid bottle and drain tube in waste pail.

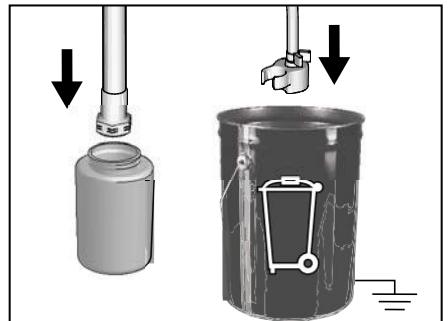

3. Turn Prime/Spray valve down to PRIME position.

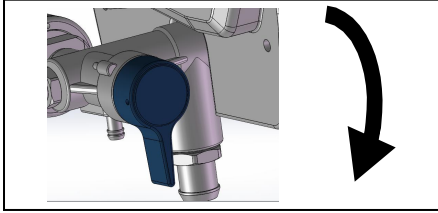

4. Turn ON/OFF switch to **ON** position.
5. Turn pressure control knob clockwise until the pump turns on.
6. When storage fluid comes out of drain tube (5-10 seconds) turn ON/OFF switch to **OFF** position.
7. Turn Prime/Spray valve horizontal to SPRAY position to keep storage fluid in sprayer during storage.

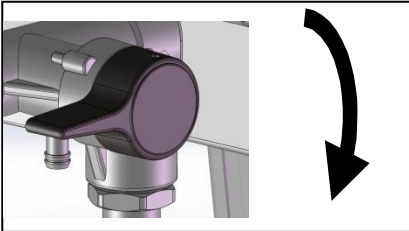

8. Leave gun attached to hose.
9. Remove tip and guard and clean with water or flushing fluid and a brush.
10. Wipe paint off outside of gun using a soft cloth moistened with water or flushing fluid.

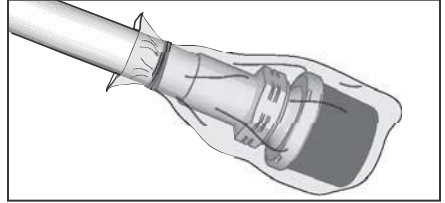

11. Secure a plastic bag around suction and drain tube to catch any drips.

Reference

Spray Tip Selection

Selecting Tip Size

Spray tips come in a variety of hole sizes for spraying a range of fluids. Your sprayer includes a tip for use in most paint spraying applications. Use the coatings table on page 17 to determine the range of recommended tip hole sizes for each fluid type. If you need a tip other than the one supplied, see the **Reversible Spray Tip Selection Chart**.

Hints:

- As you spray, the tip wears and enlarges. Starting with a tip hole size smaller than the maximum will allow you to spray within the rated flow capacity of the sprayer.
- Use larger tip hole sizes with thicker coatings and smaller tip hole sizes with thinner coatings.
- Tips wear with use and need periodic replacement.
- Tip hole size controls flow rate - the amount of paint that comes out of the gun.

Fan Width

Fan width is the size of the spray pattern, which determines the area covered with each stroke.

Hints:

- Select a fan width best suited to the surface being sprayed.
- Wider fans allow provide better coverage on broad, open surfaces.
- Narrower fans provide better control on small, confined surfaces.

Understanding Tip Number

The last three digits of tip number (i.e.:413) contain information about hole size and fan width on surface when gun is held 12 in. (30.5 cm) from surface being sprayed.

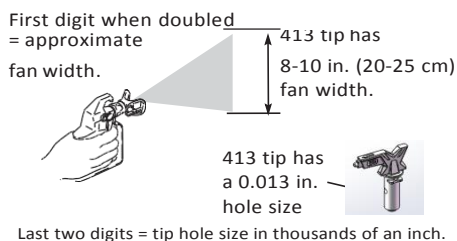

Reversible Spray Tip Selection Chart

DP Tip #	Fan Width *	Hole Size
DP-637TT DP-637TX DP-637T5	6 - 8 in. (152 - 203 mm)	0.011 in. (0.28 mm)
	8 - 10 in. (203 - 254 mm)	0.011 in. (0.28 mm)
	6 - 8 in. (152 - 203 mm)	0.013 in. (0.33 mm)
	8 - 10 in. (203 - 254 mm)	0.013 in. (0.33 mm)
	8 - 10 in. (203 - 254 mm)	0.015 in. (0.38 mm)
	10 - 12 in. (254 - 305 mm)	0.015 in. (0.38 mm)
	8 - 10 in. (203 - 254 mm)	0.017 in. (0.43 mm)
	10 - 12 in. (254 - 305 mm)	0.017 in. (0.43 mm)
* - 12 in. (305 mm) from surface		0.019 in. (0.48 mm)

Example: For an 8 to 10 in. (203 to 254 mm) fan width and 0.013 (0.33 mm) hole size.

Cleaning Fluid Compatibility

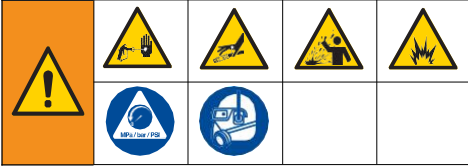

Oil- or Water-Based Materials

- When spraying **water-based** materials, flush the system thoroughly with water.
- When spraying **oil-based** materials, flush the system thoroughly with mineral spirits or compatible, oil-based flushing solvent.
- To spray **water-based** materials **after spraying oil-based** materials, flush the system thoroughly with water first. The water flowing out of drain tube should be clear and solvent-free **before** you begin spraying the water-based material.
- To spray **oil-based** materials **after spraying water-based** materials, flush the system thoroughly with mineral spirits or a compatible oil-based flushing solvent first. The solvent flowing out of the drain tube should not contain any water. When flushing with solvents always follow **Static Grounding Instructions (Oil-Based materials)**.

- To avoid fluid splashing back on your skin or into your eyes, always aim gun at inside wall of pail.

Static Grounding Instructions (Oil-Based materials)



The equipment must be grounded to reduce the risk of static sparking and electric shock. An electric or static spark can cause fumes to ignite or explode. An improper ground can cause electric shock. A good ground provides an escape wire for the electric current.

Always use a metal pail for oil-based materials requiring flushing with compatible oil-based flushing solvents when sprayer is flushed or pressure is relieved.

Follow local code. Use only conductive metal pails, placed on a grounded surface such as concrete.

Do not place pail on a non-conductive surface such as paper or cardboard which interrupts grounding continuity.



Reference

Quick Reference

Ref. No.	Name	Description
A	Prime/Spray Valve	<ul style="list-style-type: none">• In PRIME position directs fluid to drain tube.• In SPRAY position directs pressurized fluid to paint hose.• Automatically relieves system pressure in over-pressure situations.
B	Pressure Control Knob	Increases (clockwise) and decreases (counter-clockwise) fluid pressure in pump, hose, and spray gun. To select function, align symbol on pressure control knob with setting indicator.
C	ON/OFF Switch	Turns sprayer ON and OFF.
D	Suction Tube	Draws fluid from paint pail into pump.
E	Drain Tube	Drains fluid in system during priming and pressure relief.
F	Airless Spray Gun	Dispenses fluid.
G	Reversible Spray Tip	<ul style="list-style-type: none">• Atomizes fluid being sprayed, forms spray pattern and controls fluid flow according to hole size.• Reverse position unclogs plugged tips without disassembly.
H	Tip Guard	Reduces risk of fluid injection injury.
I	Gun Trigger Lock	Prevents accidental triggering of spray gun.
J	Gun Fluid Inlet Fitting	Threaded connection for paint hose.
K	Gun Fluid Filter	Filters fluid entering spray gun to reduce tip clogs.
L	Pump	Pumps and pressurizes fluid and delivers it to paint hose.
M	Pump Fluid Outlet Fitting	Threaded connection for airless hose.
N	Airless Hose	Transports high-pressure fluid from pump to spray gun.
O	Suction Filter	Prevents debris from entering pump.
P	Power Cord	Plugs into power source.
Q	Suction Tube Drip Cup	Holds the suction tube during transport to catch drips.

Maintenance

Routine maintenance is important to ensure proper operation of your sprayer.



Activity	Interval
Inspect motor shroud openings for blockage.	Daily or each time you spray
Inspect/clean filter, fluid inlet strainer, and gun filter.	Daily or each time you spray

NOTICE

Protect the internal drive parts of this sprayer from water. Openings in shroud allow cooling of mechanical parts and electronics inside. If water gets into these openings, the sprayer could malfunction or be permanently damaged.

High Pressure Airless Hoses

Check hose for damage every time you spray. Do not attempt to repair hose if hose jacket or fittings are damaged. Do not use hoses shorter than 25 ft (7.6 m). Wrench tighten, using two wrenches.

Spray Tips

- Always clean tips with compatible cleaning fluid and brush after spraying.
- Tips may require replacement after 15 gallons (57 liters) or they may last through 60 gallons (227 liters) depending on abrasiveness of paint.

Pump Removal

Remove the hopper on sprayers with a hopper. Remove airless hose, it may also be necessary to remove the suction tube.

Always perform **Pressure Relief Procedure**, page 9, before starting any pump repairs and unplug the sprayer.

1. Unplug the sprayer from the power source.
2. Screw out the fixing screws and taking down the front cover.

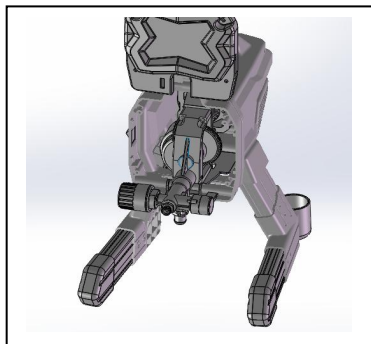

3. Now slowly take out the fluid pump out.

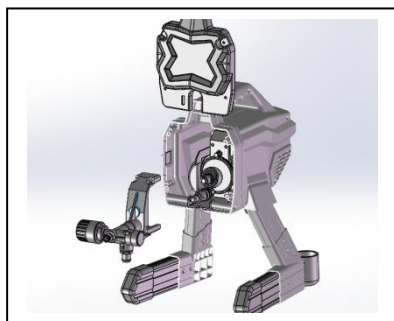

Maintenance

Inlet Valve Removal and Installation

If you suspect that the inlet valve is clogged or stuck, remove the valve assembly and clean or replace.

1. Remove suction tube or hopper from sprayer.
2. Loosen the inlet valve. Remove inlet valve.

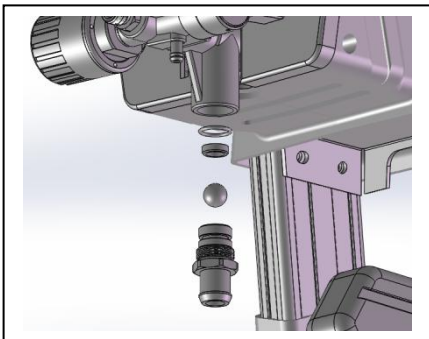

3. Clean any debris and dried paint from the cavity and replace the ball and spring. Tighten inlet valve to pump using proper tool on the frame.
4. Please pay attention to the conical spring direction when installing back the ball and conical spring.

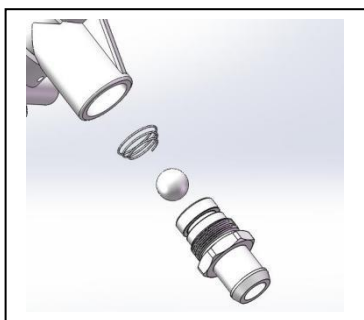

NOTICE

Do not lose the ball and spring inside the inlet valve assembly. It may fall out when the inlet valve is removed. Pump will not prime without the ball and spring.

Piston Rod and Pump Installation

1. The piston rod and V-packings of DP-X3 and DP-X5 are replaceable, as below.

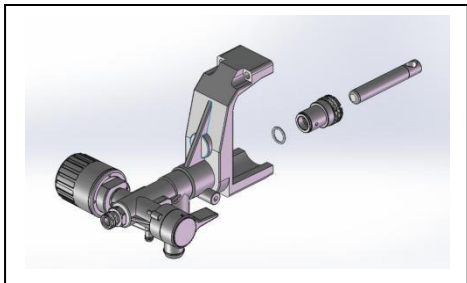

2. Install the pump assembly back to the gear box.

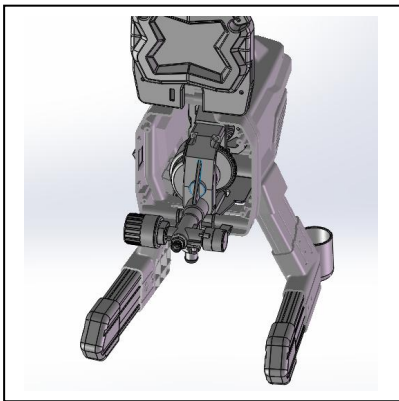

- a. Move pump rod up or down until cap is level with the opening in the yoke.
- b. Push on pump rod to slide pump assembly back on to mounting pins.

3. Put on the front cover and fix the screws.

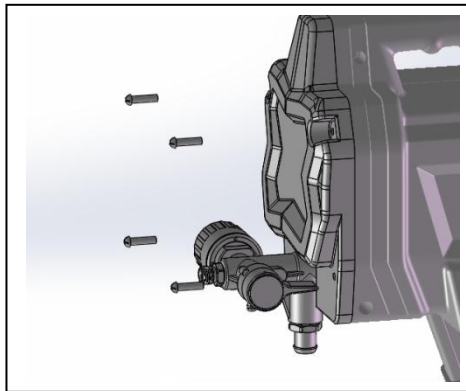

4. Install any hoses removed earlier.

5. Plug sprayer into power source.

NOTE: Door must be fully closed and latched before sprayer will operate.

Troubleshooting

3. Check everything in this Troubleshooting Table before you bring the sprayer to an authorized service center.

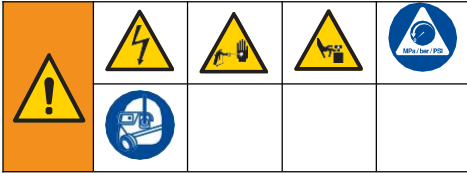

1. Follow Pressure Relief Procedure, page 9, before checking or repairing.
2. Solutions at the beginning of each problem listed are the most common.

Problem	Cause	Solution
Motor does not run: (verify sprayer is plugged in, and ON/OFF switch is on)	Pressure control is set at zero pressure.	Turn pressure control knob clockwise to increase pressure setting.
	Electric outlet is not providing power.	Test outlet with known working device. Reset circuit breaker or replace fuse. Find working outlet. Reset building circuit breaker or replace fuse.
	Extension cord is damaged.	Replace extension cord.
	Sprayer electric cord is damaged.	Check for broken insulation or wires. Replace electric cord if damaged.
	Pump is seized (Paint has hardened in pump or Water is frozen in pump.)	Turn ON/OFF switch off and unplug sprayer from outlet. If frozen do NOT try to start sprayer until it is completely thawed or it may damage the motor, control board and/or drivetrain. Place sprayer in warm area for several hours. Check for free moving pump by removing shroud and spinning fan. If not frozen, check for hardened paint in pump. If paint has hardened in pump. If motor does not turn with pump removed, consult a Graco/ Magnum authorized retailer, distributor, or service center.
Motor or control is damaged.	Consult a P authorized retailer, distributor, or service center.	

Problem	Cause	Solution
<p>Sprayer runs, but pump does not prime or loses prime while in use.</p> <p>(Pump cycles but does not pump paint or build pressure.)</p>	Inlet valve check ball is stuck.	Press PushPrime button to dislodge the ball allowing pump to prime properly.
	Prime/Spray valve is in SPRAY position.	Turn Prime/Spray valve down to PRIME position until paint exits drain tube. The pump is now primed.
	Pump was not primed with flushing fluid. (Thick fluids may not prime if not initially primed with flushing fluid.)	Remove suction tube from paint. Prime pump with oil or water-based flushing fluid.
	Debris in paint.	Strain the paint.
	Thick or “sticky” paint.	Some fluids may prime faster if the ON/OFF switch is momentarily turned off so the pump can slow and stop. Turn ON/OFF switch on and off several times if necessary.
	Inlet strainer is clogged or suction tube is not immersed in paint.	Clean debris off inlet strainer and make sure suction tube is immersed in paint.
	Inlet valve check ball or seat is dirty.	Remove inlet fitting. Clean or replace ball and seat.
	Suction tube is leaking.	Inspect suction tube connection for cracks or vacuum leaks.
	Outlet valve check ball is stuck.	Unscrew outlet valve, remove, and clean assembly.
	Prime/Spray valve is worn or obstructed with debris.	Take sprayer to DINO-POWER authorized service center.

Troubleshooting

Problem	Cause	Solution
Pump is primed, but can not achieve good spray pattern.	Spray tip may be partially clogged.	Clear spray tip clog.
	Reversible spray tip is in UNCLOG position.	Rotate arrow-shaped handle on spray tip so it points forward to SPRAY position.
	Debris in paint.	Strain the paint.
	Pressure is set too low.	Align pressure control knob setting indicator to desired spray setting.
	Spray gun fluid filter is clogged.	Clean or replace gun fluid filter.
	Spray tip selected is too large for capability of sprayer.	Replace tip.
	Spray tip is worn beyond the capability of sprayer.	Replace tip.
	Spray tip gasket and seal worn or missing.	Replace gasket and seal.
	Inlet strainer is clogged or suction tube is not immersed in paint.	Clean debris off inlet strainer and make sure suction tube is immersed in paint.
	Extension cord is too long or not heavy enough gauge.	Replace extension cord.
	Inlet pump valve or outlet pump valve is worn or clogged with debris.	Check for worn or contaminated inlet valve or outlet valve. <ul style="list-style-type: none"> - Prime sprayer with paint - Trigger gun momentarily - When trigger is released, pump should cycle momentarily and stop - If pump continues to cycle, pump valves may be worn or contaminated with debris - Clean and reinstall valves
	Material is too thick.	Thin material. Follow manufacturers recommendations.
Airless hose is too long (if extra section was added).	Remove section of airless hose.	
Spray gun stopped spraying while trigger is pulled.	Spray tip is clogged.	Clear spray tip clog.
	Sprayer lost prime.	See troubleshooting section "Sprayer runs, but pump does not prime or loses prime while in use."

Problem	Cause	Solution
When paint is sprayed, it runs down the wall or sags.	Material is going on too thick.	Move gun faster.
		Choose a spray tip with smaller hole size.
		Choose spray tip with wider fan.
		Make sure gun is far enough from surface.
When paint is sprayed, coverage is inadequate.	Material is going on too thin.	Move gun slower.
		Choose spray tip with larger hole size.
		Choose spray tip with narrower fan.
		Make sure gun is close enough to surface.
Fan pattern varies dramatically while spraying.	Pressure control switch is worn and causing excessive pressure variation.	Take sprayer to DINO-POWER authorized service center.
Cannot trigger spray gun.	Spray gun trigger lock is engaged.	Rotate trigger lock to disengage trigger lock.
Paint is coming out of pressure control switch.	Pressure control switch is worn.	Take sprayer to DINO-POWER authorized service center.
Paint is leaking through drain tube.	Sprayer is over pressurizing.	Take sprayer to DINO-POWER authorized service center.
Paint leaks down outside of pump.	Pump packings are worn.	Replace pump packings
Motor is hot and runs intermittently. Motor automatically shuts off due to excessive heat. Damage can occur if cause is not corrected.	Vent holes in enclosure are plugged or sprayer is covered.	Keep vent holes clear of obstructions and overspray and keep sprayer open to air.
	Extension cord is too long or not a heavy enough gauge.	Replace extension cord.
	Unregulated electrical generator being used has excessive voltage.	Use electrical generator with a proper voltage regulator.
	Motor needs to be replaced.	Take sprayer to DINOPOWER authorized retailer, distributor, or service center.

DP-X3 DP-X5 Electric Airless Paint Sprayer

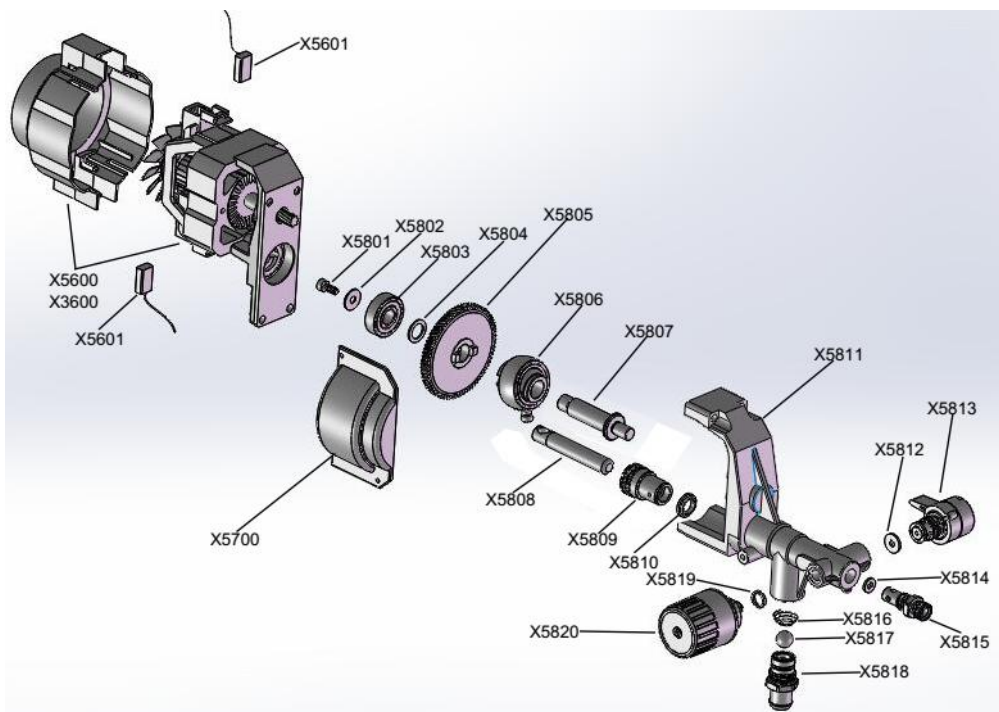
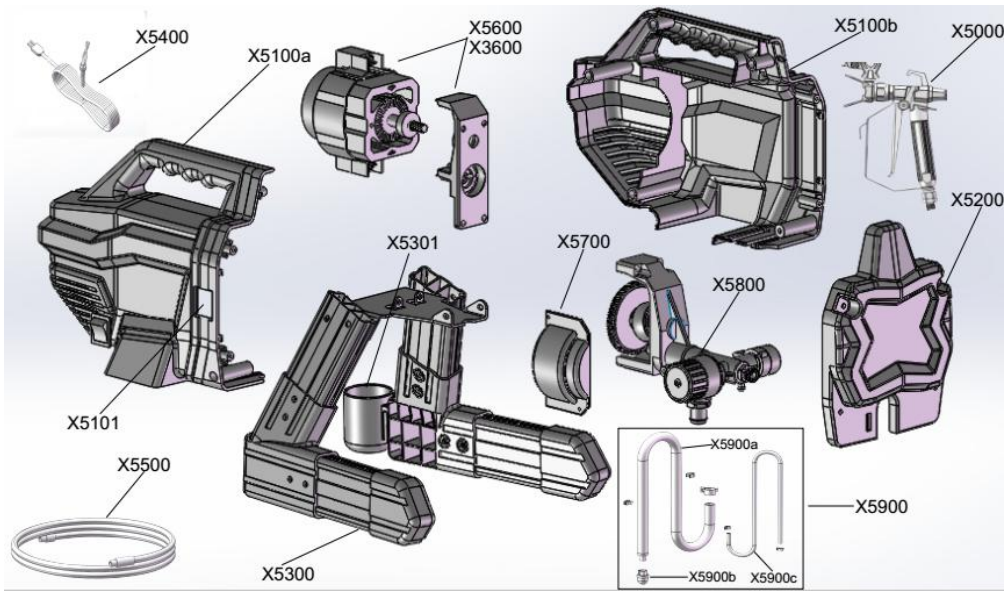

Spare Parts List for DP-X3 DP-X5

Parts No.	Description	QTY
X5100a	Left cover	1
X5100b	Right cover	1
X5200	Front cover	1
X5300	Stand Assembly	1
X5301	Drip cup	1
X5400	Plug	1
X5500	High pressure hose 1/4"*7.5m	1
X5600	X5 motor assembly	1
X3600	X3 motor assembly	
X5601	Carbon brush	2
X5700	Gear Cover	1
X5800	Pump assembly	1
X5801	Screw	1
X5802	Gasket	1
X5803	Bearing 6201-2Z	1
X5804	O-ring	1
X5805	Gear	1
X5806	Pendulum bearings	1
X5807	Pendulum mandrel	1
X5808	Piston Rod	1
X5809	Sleeve	1
X5810	O-ring	1
X5811	Fulid Pump	1
X5812	Gasket	1
X5813	Prime valve	1
X5814	O-ring	1
X5815	Outlet valve	1
X5816	Spring	1
X5817	Inlet valve ball	1
X5818	Inlet Valve	1
X5819	O-ring	1
X5820	Pressure regulator	1
X5900	Suction/Prime assembly	1
X5900a	Suction tube	1
X5900b	Suction filter	1
X5900c	Prime tube	1
X5000	Airless spray gun	1

DP Information

For the latest information about DP productions, please visit official website www.dpairless.com .



Ningbo Dino-power Machinery Co., Ltd.

Add: No. 168, Mingguang Road, Yinzhou, Ningbo, China, 315100.

Tel: +86-574-88278841, +86-574-88278841

Fax: +86-574-88278841

Facebook - <http://www.facebook.com/dp.airless>

Twitter - <https://twitter.com/DPAirless>

Youtube - <http://www.youtube.com/user/dpairless.com>

Google+ - <https://plug.google.com/u/0/+DpAirlesspaintsprayer/>

Skype: dino-power

WeChat: +86-13566005805

Whatsapp: +86-13566005805